

Alderon

Papan Proyek[®]
Daur Ulang



Papan Proyek

uPVC Alderon

Papan Proyek uPVC Alderon adalah pengganti pagar pembatas proyek tradisional yang lebih modern, terbuat dari bahan unplasticized Poly Vinyl Chloride (uPVC).

The uPVC Alderon Project Board is a modern alternative to traditional project boundary fences. It is made from unplasticized Poly Vinyl Chloride (uPVC) material.



Spesifikasi & Data Teknis / Specification & Technical Data

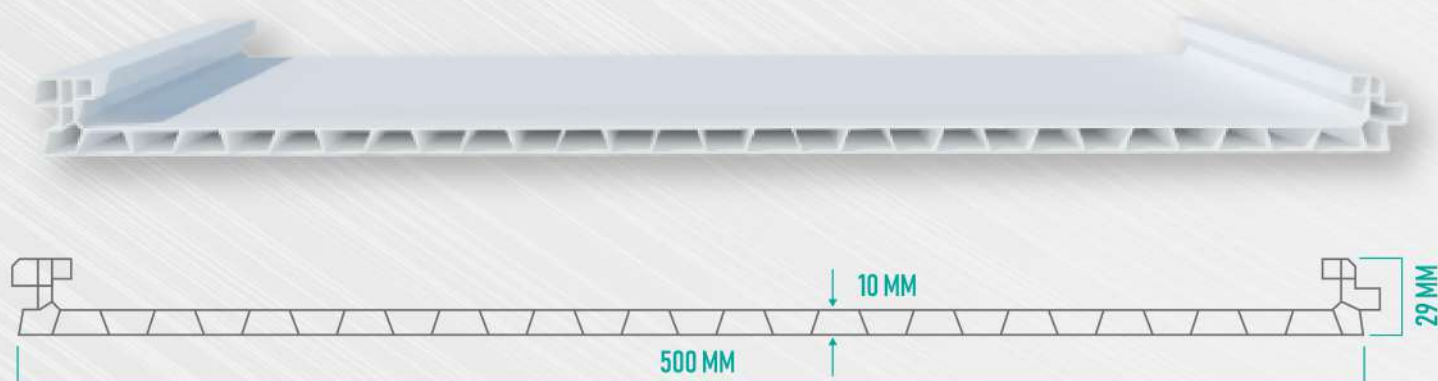

Fitur dari Papan Proyek uPVC Alderon :

Features of Alderon uPVC Project Board :

- ◆ **Tahan air**
Water resistance
- ◆ **Tidak korosi**
Corrosion resistance
- ◆ **Mudah dipasang**
Easy Installation
- ◆ **Bisa dipakai berkali-kali**
It can be used repeatedly.
- ◆ **Tidak merambatkan api**
Fire retardant
- ◆ **Tahan bahan kimia**
Chemical resistant
- ◆ **Permukaan rata**
Flat surface
- ◆ **Ringan**
Light Weight
- ◆ **Dapat didaur ulang Kembali.**
Recyclable.

Tebal Thickness	10 mm
Lebar Width	500 mm
Berat Weight	2 kg/lm
Panjang Length	Up to 6 m
Aplikasi Application	Tongue dan Groove
Warna Color	White
Aksesoris Accessories	Clamp
Fire Rating	UL 94 V0 ASTM E 108 Class A

Instalasi / Installation

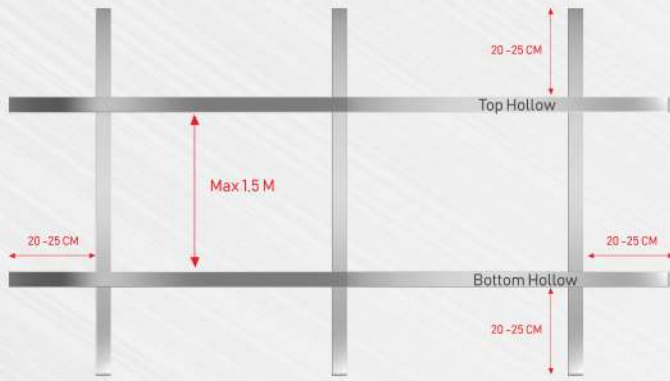

- 1. Siapkan terlebih dahulu rangka hollow 40x40 mm.**
Prepare in advance the 40x40 mm hollow frame.

Siapkan Hollow 40x40 mm Jarak antara hollow disesuaikan dengan kebutuhan lapangan, maksimum 1.5 m antara hollow atas dan bawah.

Set up a 40x40 mm Hollow. The distance between the hollows is adjusted to the needs of the field, a maximum of 1.5 m between the upper and lower hollows.



- 2. Potong panjang papan proyek uPVC Alderon sesuai kebutuhan.**
Cut the length of Alderon's uPVC project board as needed.

- 3. Siapkan aksesories clamp untuk menyatukan antara 2 papan proyek uPVC Alderon.**

Prepare clamp accessories to unite between 2 Alderon uPVC project boards.

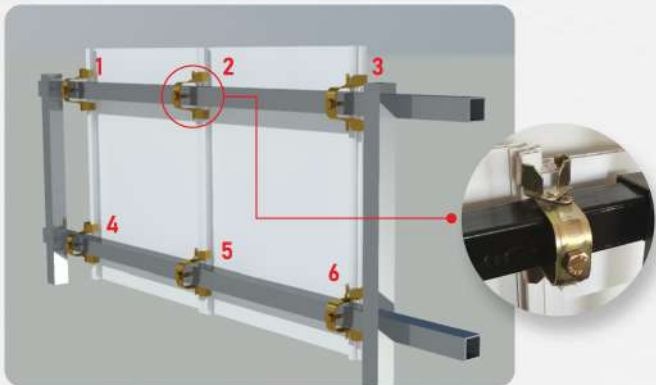

- 4. Selanjutnya pasang modul secara berurutan sampai dengan modul terakhir.**

Next, install the modules sequentially up to the last module.

Penanganan & Penyimpanan / Handling & Storage

- ◆ **Gunakan jigsaw atau circular saw dengan gigi yang halus (dekat-dekat)**
Use a jigsaw or circular saw with fine teeth (close by)
- ◆ **Setting pada kecepatan putaran tinggi dengan kecepatan memotong pelan.**
Setting at high rotation speed with slow cutting speed.
- ◆ **Gunakan penahan/support untuk meredam getaran akibat jigsaw & circular saw.**
Use a support to dampen vibrations caused by jigsaws & circular saws.
- ◆ **Bersihkan debu dan serpihan setelah proses pemotongan selesai.**
Remove dust and debris after the cutting process is complete.
- ◆ **Simpan pada tempat yang kering, lindungi dari sinar matahari langsung & hujan.**
Store in a dry place. Protect from direct sunlight & rain.
- ◆ **Hindari menggunakan penutup yang menyerap panas.**
Avoid using heat-absorbing covers.
- ◆ **Hindari kontak langsung dengan lingkungan bahan kimia.**
Avoid direct contact with chemical environments.
- ◆ **Hindari penyimpanan diletakan pada area yang berpotensi tertimpa barang atau kerusakan fisik lainnya.**
Avoid storage placed in areas that have the potential to be hit by goods or other physical damage.
- ◆ **Lakukan pekerjaan sesuai dengan peraturan keselamatan kerja yang berlaku ditempat tersebut.**
Perform work in accordance with the applicable work safety regulations in the place.



Manufactured by / Diproduksi oleh :



PT. Unipack Plasindo

a subsidiary of **PT Impact Pratama Industri Tbk**
Excellence through Passion

Distributed by / Didistribusikan oleh :

